

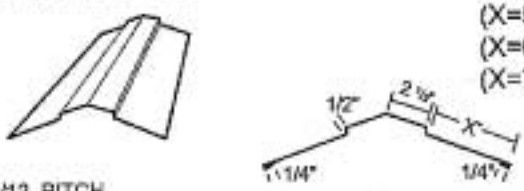









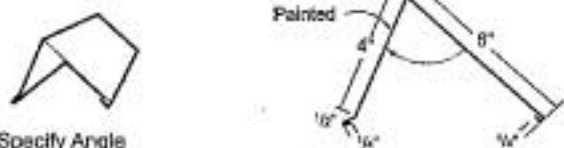

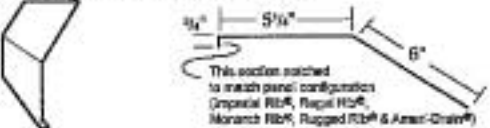
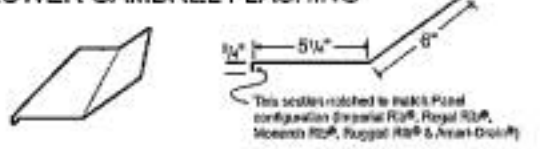

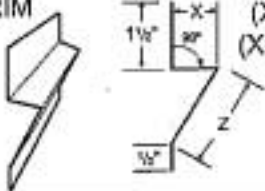

29 GAUGE TRIM

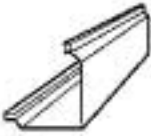
ITEM	DESCRIPTION				NOTES
	PART NO.	LENGTH	GIRTH	WEIGHT	
PLAIN RIDGE CAP  4/12 PITCH	(X=4")	LG-101	10' - 6"	14 1/2"	7.39 #
	(X=5")	LG-101A	10' - 6"	16 1/2"	8.20 #
	(X=6")	LG-101B	10' - 6"	18 1/2"	9.30 #
	(X=7")	LG-101C	10' - 6"	20 1/2"	10.33 #
ADJUSTABLE RIDGE CAP - Two Pieces  Notched to match panel configuration (Imperial Rib® & Regal Rib®)		LG-102	3' - 3"	18 3/4"	2.87 #
	Imp Rib	LG 102A	3' - 3"	18 3/4"	2.87 #
	Reg Rib	LG 102B	3' - 3"	18 3/4"	2.87 #
	Am-Dr				
DENVER PEAK TRIM  Painted Specify Angle		LG-103	10' - 6"	11"	5.25 #
ENDWALL FLASHING  Specify Angle Notched to match panel configuration (Imperial Rib®, Regal Rib®, Monarch Rib®, Rugged Rib®, and Ameri-Drain®)		LG-104 (Imp)	3' - 3"	12"	1.84 #
		LG-104A (Reg)			
		LG-104B (Am)			
		LG-104C (Rug)			
		LG-104D (Mon)			
UPPER GAMBREL FLASHING  This section notched to match panel configuration (Imperial Rib®, Regal Rib®, Monarch Rib®, Rugged Rib®, and Ameri-Drain®)		LG-105 (Imp)	3' - 3"	12"	1.84 #
		LG-105A (Reg)			
		LG-105B (Am)			
		LG-105C (Rug)			
		LG-105D (Mon)			
LOWER GAMBREL FLASHING  This section notched to match panel configuration (Imperial Rib®, Regal Rib®, Monarch Rib®, Rugged Rib®, and Ameri-Drain®)		LG-106 (Imp)	3' - 3"	12"	1.84 #
		LG-106A (Reg)			
		LG-106B (Am)			
		LG-106C (Rug)			
		LG-106D (Mon)			
DENVER ENDWALL FLASHING  Painted Specify Angle		LG-107	10' - 6"	9 3/4"	4.41 #
SIDEWALL FLASHING 		LG-108	10' - 6"	8 3/4"	4.02 #
DENVER SIDEWALL FLASHING  Painted		LG-109	10' - 6"	8 1/4"	4.41 #

29 GAUGE TRIM

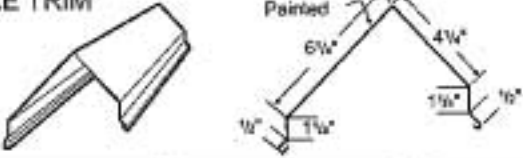
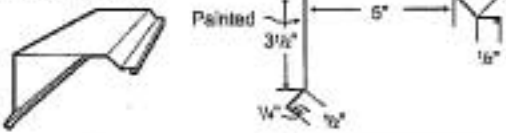

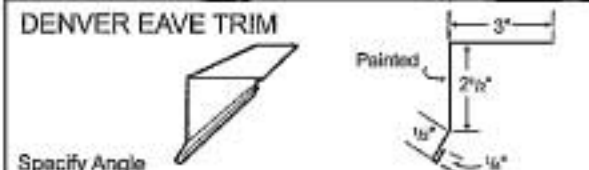
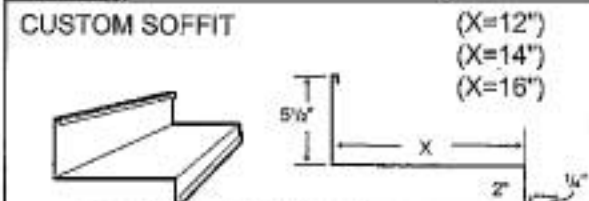
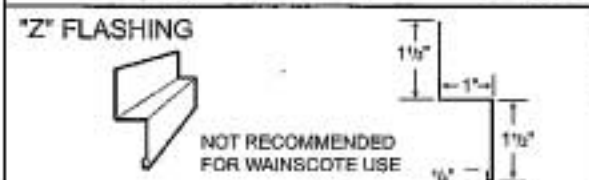
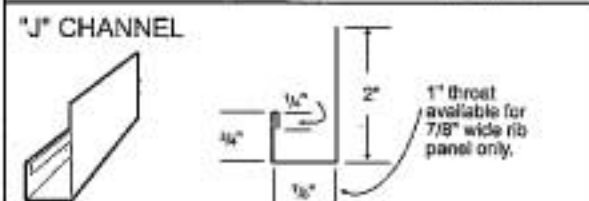
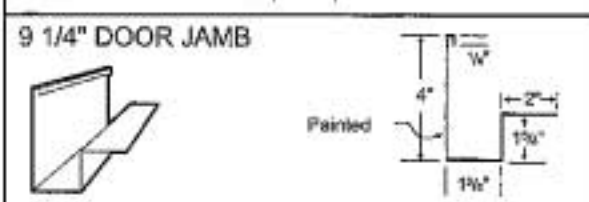
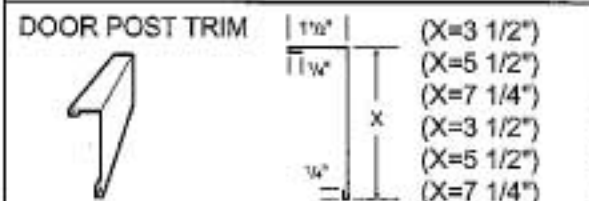
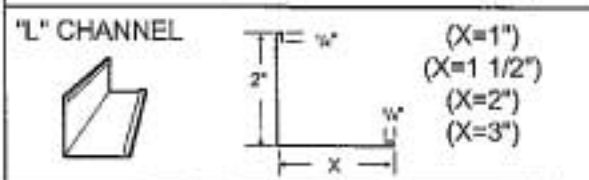
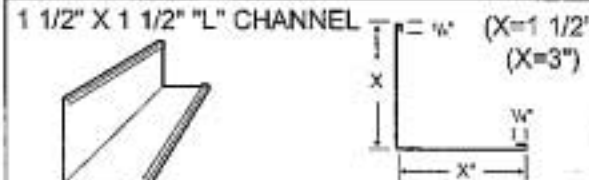

ITEM	DESCRIPTION				NOTES
	PART NO.	LENGTH	GIRTH	WEIGHT	
BASE TRIM 	(X=1")(Z=1 13/16") LG-110	10' - 6"	4 13/16"	2.46 #	
	(X=1 1/2")(Z=2 1/4") LG-110A	10' - 6"	5 3/4"	2.98 #	
SQUARE BASE ANGLE 	(X=1") LG-111	10' - 6"	4 3/4"	2.46 #	
	(X=1 1/2") LG-111A	10' - 6"	5 3/4"	2.98 #	
DOOR & EDGE CAP 	LG-112	10' - 6"	6 1/2"	3.49 #	
CORNER TRIM 	LG-113	10' - 6"	12 1/2"	6.73 #	
	LG-113A	12' - 6"	12 1/2"	8.06 #	
	LG-113B	14' - 6"	12 1/2"	9.41 #	
	LG-113C	16'	12 1/2"	10.75 #	
3" X 3" CORNER TRIM 	LG-114	10' - 6"	10"	5.36 #	
INSIDE CORNER 	LG-115	10' - 6"	12 1/2"	6.70 #	
SHINGLE RAKE TRIM 	LG-116	10' - 6"	9 1/2"	5.23 #	
RAKE TRIM 	LG-117	10' - 6"	14 1/2"	7.89 #	
	LG-117A	16'	14 1/2"	12.64 #	
DENVER GABLE 	LG-118	10' - 6"	11 1/4"	6.03 #	

29 GAUGE TRIM

ITEM	DESCRIPTION				NOTES
	PART NO.	LENGTH	GIRTH	WEIGHT	
EAVE FLASHING  <p>Specify Angle</p>	LG-119	10' - 6"	9 1/2"	5.23 #	
DENVER EAVE TRIM  <p>Specify Angle</p>	LG-120	10' - 6"	6 1/4"	3.50 #	
CUSTOM SOFFIT  <p>(X=12") (X=14") (X=16")</p>	LG-121 LG-121A LG-121B	10' - 6" 10' - 6" 10' - 6"	20" 22" 24"	10.71 # 11.75 # 12.85 #	
"Z" FLASHING  <p>NOT RECOMMENDED FOR WAINSCOTE USE</p>	LG-122	10' - 6"	4 1/4"	2.28 #	
"J" CHANNEL 	LG-123 LG123A	10' - 6" 16'	3 7/8" 3 7/8"	2.32 # 4.2 #	
9 1/4" DOOR JAMB  <p>Painted</p>	LG-125	10' - 6"	9 1/2"	5.09 #	
DOOR POST TRIM 	LG-126 LG-126A LG-126B LG-126C LG-126D LG-126E	10' - 6" 10' - 6" 10' - 6" 16' 16' 16'	5 1/2" 7 1/2" 9 1/4" 5 1/2" 7 1/2" 9 1/4"	2.95 # 4.02 # 4.96 # 4.50 # 6.13 # 7.55 #	
"L" CHANNEL 	LG-127 LG-127A LG-127B LG-127C	10' - 6" 10' - 6" 10' - 6" 10' - 6"	3 1/2" 4" 4 1/2" 5 1/2"	1.88 # 2.14 # 2.43 # 2.95 #	
1 1/2" X 1 1/2" "L" CHANNEL 	LG-128 LG-128A	10' - 6" 10' - 6"	3 1/2" 6 1/2"	1.88 # 3.76 #	

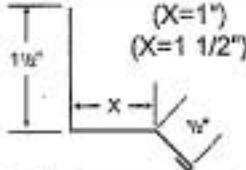
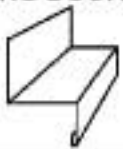
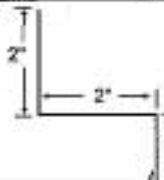
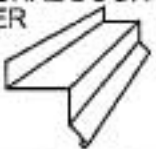
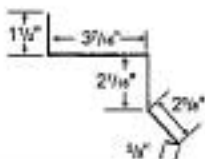
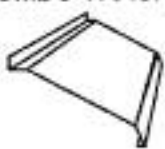
SUBJECT TO CHANGE WITHOUT NOTICE
EFFECTIVE DATE AUGUST 2, 2004

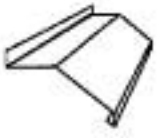
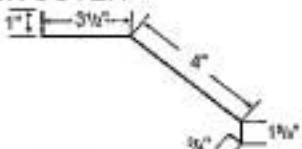
29 GAUGE TRIM

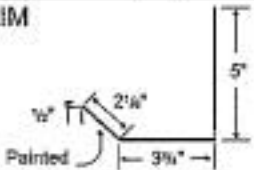
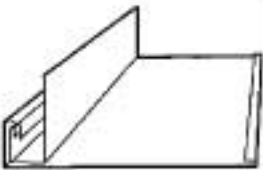
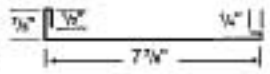
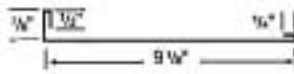
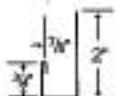
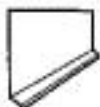
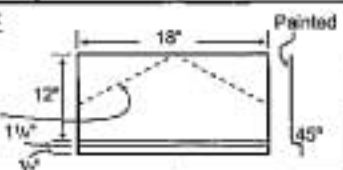
ITEM	DESCRIPTION				NOTES	
	PART NO.	LENGTH	GIRTH	WEIGHT		
WINDOW DRIP CAP 	 <p>(X=1") (X=1 1/2")</p>	LG-129	10' - 6"	3 1/4"	1.60 #	
		LG-129A	10' - 6"	3 3/4"	1.88 #	
SLIDING DOOR DRIP CAP 		LG-130	10' - 6"	5 1/4"	4.42 #	
NATIONAL DOOR TRACK COVER 		LG-131	10' - 6"	10 3/8"	5.48 #	
		LG-131A	16'	10 3/8"	8.35 #	
COMBO TRACK COVER 		LG-132	10' - 6"	12"	6.3 #	
		LG-132A	16'	12"	9.6 #	
		NOTE: May also be used with CANONBALL TRACK				
TOP MOUNT TRACK COVER 		LG-133	10' - 6"	10 7/8"	5.57 #	
		LG-133A	16'	10 7/8"	8.5 #	
TRACK DOOR JAMB TRIM 	 <p>Painted</p>	LG-134	10' - 6"	11 5/8"	6.3 #	
OVERHEAD DOOR ASSEMBLY 	OVERHEAD DOOR ADAPTOR (7 7/8") 	LG-235	10' - 6"	9 1/2"	6.5 #	
	LG-235A	16'	9 1/2"	10.4 #		
	OVERHEAD DOOR ADAPTOR (9 1/8") 	LG-236	10' - 6"	10 3/4"	7.65 #	
		LG-236A	16'	10 3/4"	12.2 #	
		STANDARD "J" 	LG-123	10' - 6"	3 7/8"	2.32 #
		LG-123A	16'	3 7/8"	4.20 #	
		NON-EXPOSED J ASSORTED COLORS MAY BE USED				
KEYSTONE PIECE 	 <p>Painted</p> <p>Field out to match roof pitch.</p>	LG-137	12"X18"	N/A	1 #	

29 GAUGE TRIM

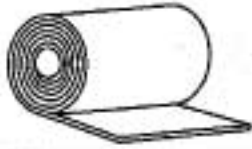
ITEM	DESCRIPTION						NOTES
	PART NO.	GENERAL	LENGTH	GIRTH	WEIGHT		
"W" FORMED VALLEY 	X= 9"	LG-138	29 Gauge Steel Available in All Colors	10' - 6"	20"	10.30 #	
	X=14"	LG-139		10' - 6"	30"	15.45 #	
4:12 PITCH STANDARD UNLESS SPECIFIED OTHERWISE							
ROLL VALLEY 	29 GAUGE		29 Gauge Steel Available in All Colors	50'-0"	20 3/16"	65 #	